



Professional
MotorSport
WORLD EXPO 2006

ZEROSHIFT

How will it help you win?

Richard Thompson

Senior Design Engineer (Motorsport)



PRESENTATION OVERVIEW

- Concept
- Considerations for an instant gearshift
- Development
- Managing a 'Zeroshift'
- Data collection and analysis
- Benefits

ZEROSHIFT

Professional
MotorSport
WORLD EXPO 2006



CONCEPT

Synchromesh engagement transmission

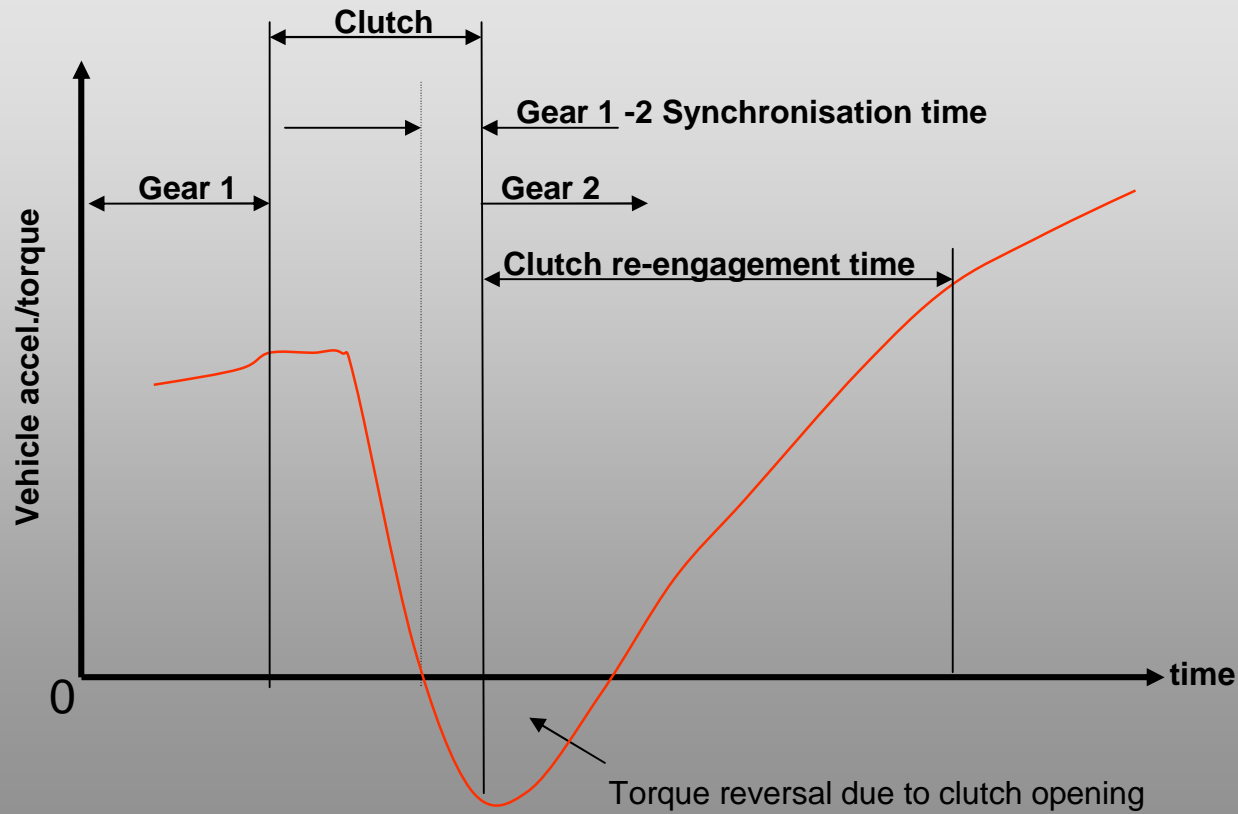

ZEROSHIFT

Professional
MotorSport
WORLD EXPO 2006



CONCEPT

Dog engagement transmission

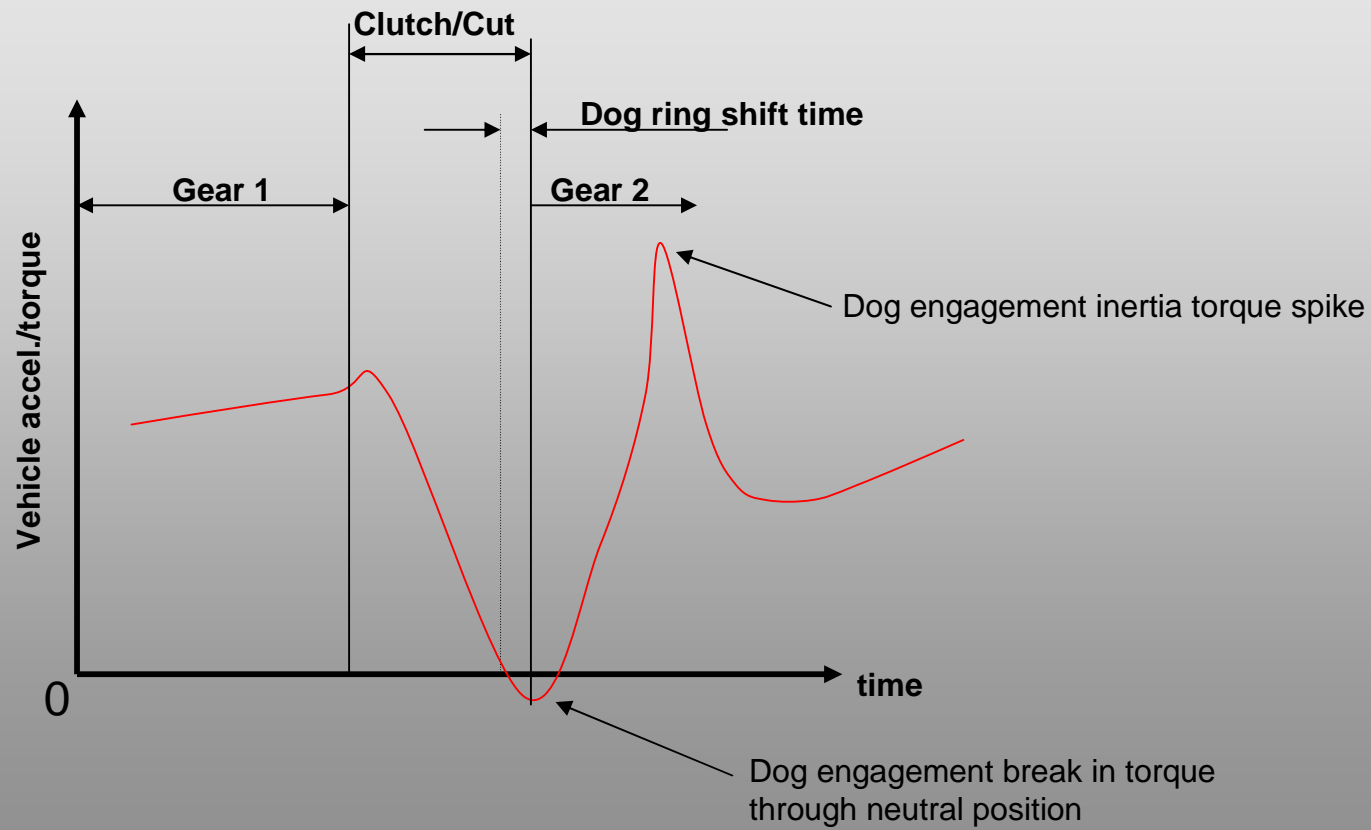

ZEROSHIFT

Professional
MotorSport
WORLD EXPO 2006



CONCEPT

Synchromesh/Dog envelope

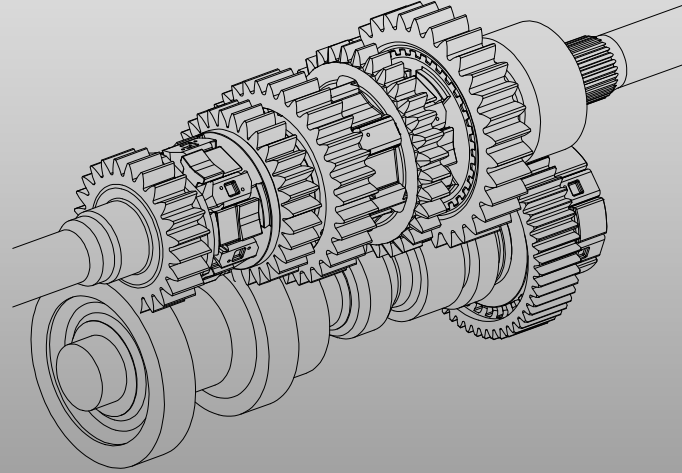
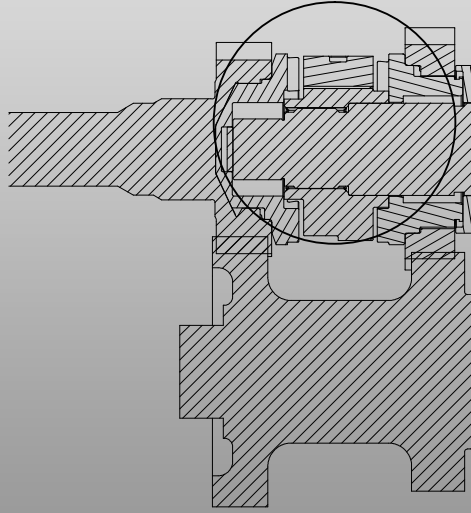

ZEROSHIFT

Professional
MotorSport
WORLD EXPO 2006



CONCEPT

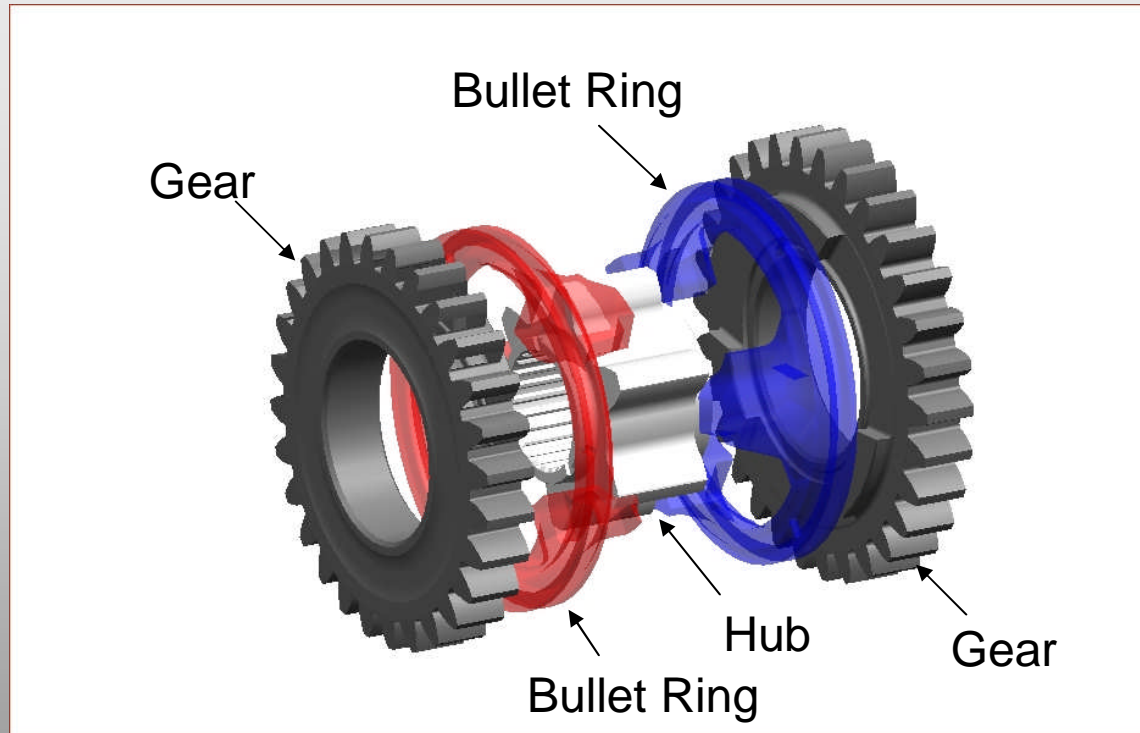

PLAY ANIMATION

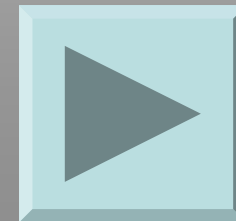

ZEROSHIFT

Professional
MotorSport
WORLD EXPO 2006



PRESENTATION OVERVIEW

- Concept
- Considerations for an instant gearshift
- Development
- Managing a 'Zeroshift'
- Data collection and analysis
- Benefits

ZEROSHIFT

Professional
MotorSport
WORLD EXPO 2006



CONSIDERATIONS FOR AN INSTANT GEARSHIFT

- Shift event

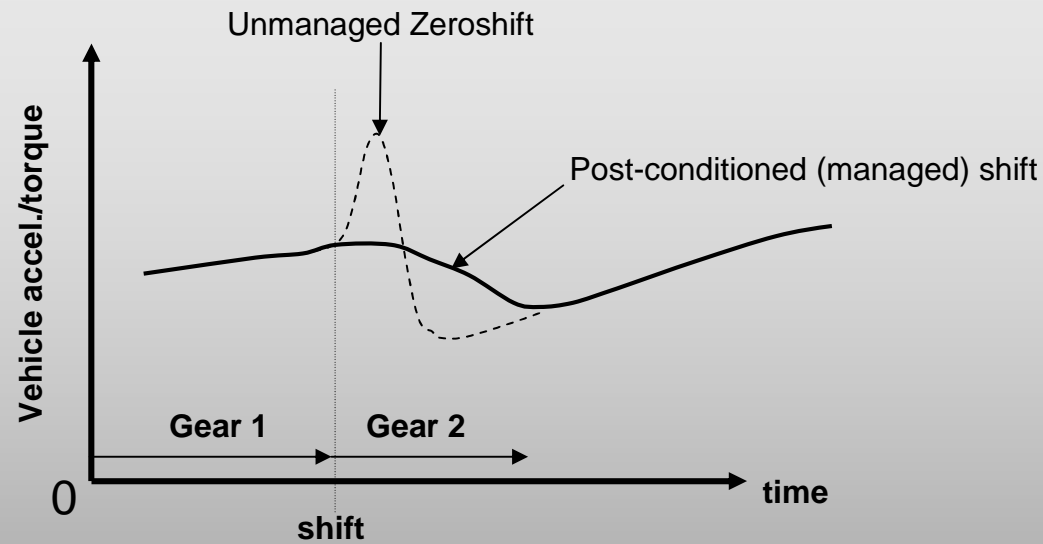

- Engine inertia torque
- Driveability and shift quality

ZEROSHIFT

Professional
MotorSport
WORLD EXPO 2006



PRESENTATION OVERVIEW

- Concept
- Considerations for an instant gearshift
- Development
- Managing a 'Zeroshift'
- Data collection and analysis
- Benefits

ZEROSHIFT

Professional
MotorSport
WORLD EXPO 2006



DEVELOPMENT

Development car

Ford Mustang V6 4.0L

Configuration V6

Output 210 bhp @ 5300 rpm $.7355 = 154 \text{ kW}$

Torque 240 lb.ft @ 3500 rpm $\times 1.356 = 325 \text{ Nm}$

Kerb weight 1500 kg

HP/Kerb weight 140 bhp per tonne

Length 4765 mm

Height 1384 mm

Width 1877 mm



New Zeroshift Transmission ZS01

6-speed sequential AMT

Single-plate dry clutch

Closed loop electro-mechanical clutch control

ZEROSHIFT

Professional
MotorSport
WORLD EXPO 2006



DEVELOPMENT

Controls and Electronics

- Zeroshift TCU (Zeroshift hardware and software)
- In-house transmission control algorithms
- Electro-pneumatic, Electro-hydraulic and Electric-mechanical shift systems.
- High-speed (kHz) datalogging of transmission internal speeds, driveline torques and vehicle CAN data

ZEROSHIFT

Professional
MotorSport
WORLD EXPO 2006



PRESENTATION OVERVIEW

- Concept
- Considerations for an instant gearshift
- Development
- Managing a 'Zeroshift'
- Data collection and analysis
- Benefits

ZEROSHIFT

Professional
MotorSport
WORLD EXPO 2006



MANAGING A 'ZEROSHIFT'

Dog vs Zeroshift (unmanaged)

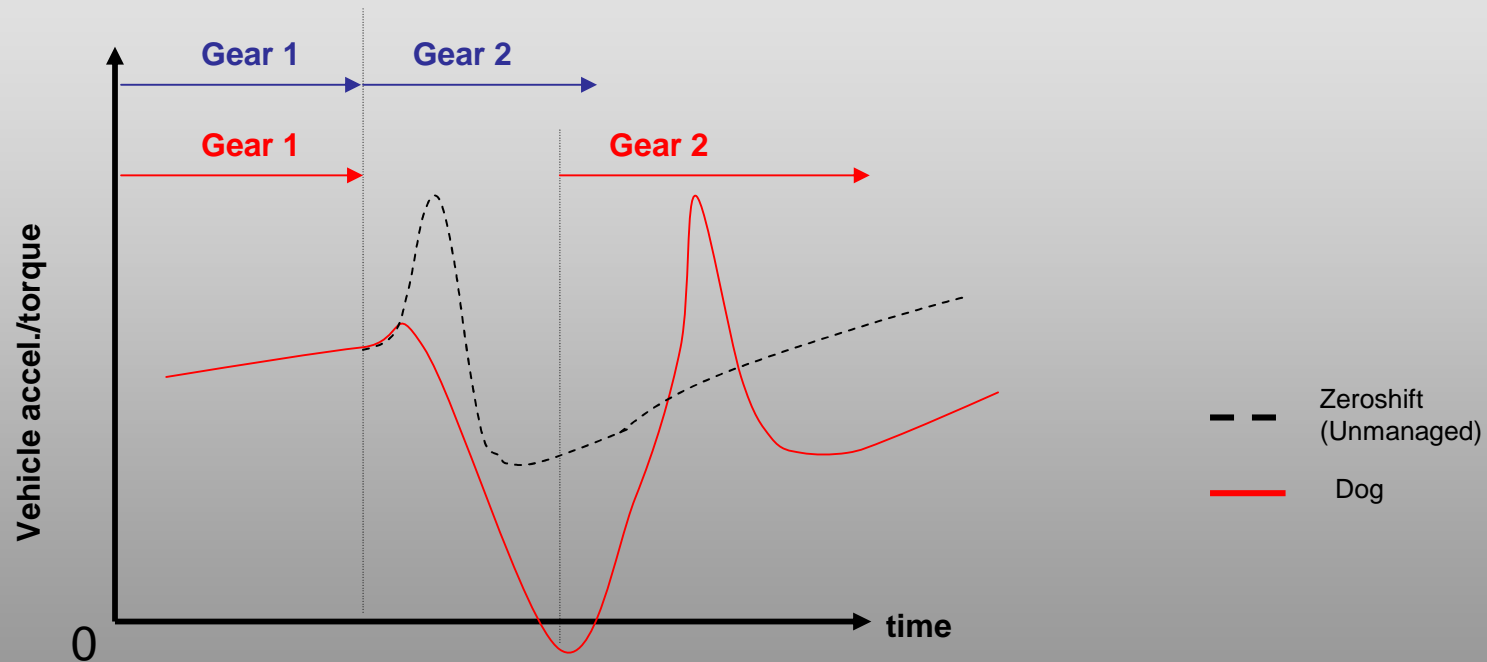

ZEROSHIFT

Professional
MotorSport
WORLD EXPO 2006



MANAGING A 'ZEROSHIFT'

Dog vs Zeroshift (managed)

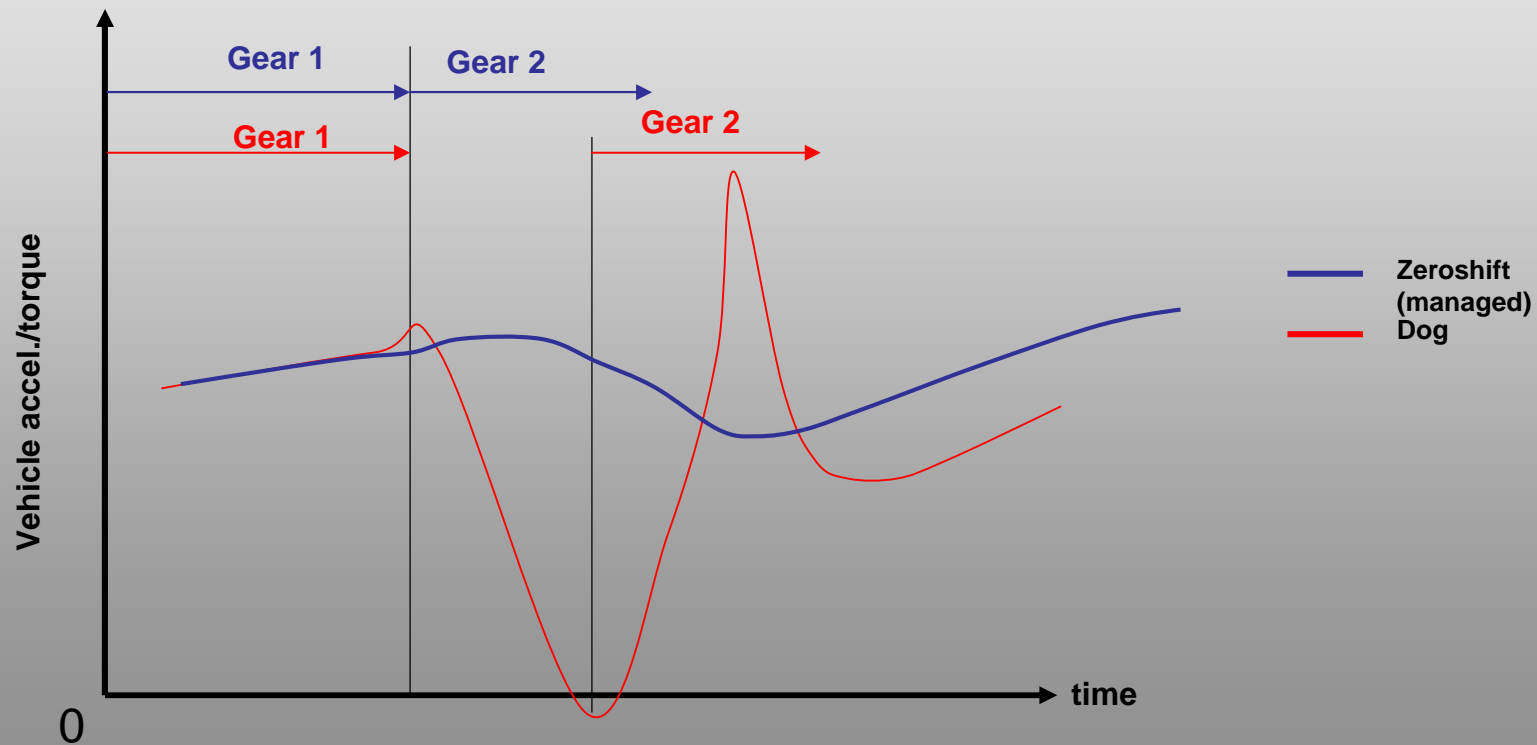

ZEROSHIFT

Professional
MotorSport
WORLD EXPO 2006



MANAGING A 'ZEROSHIFT'

Synchro vs Zeroshift (managed)

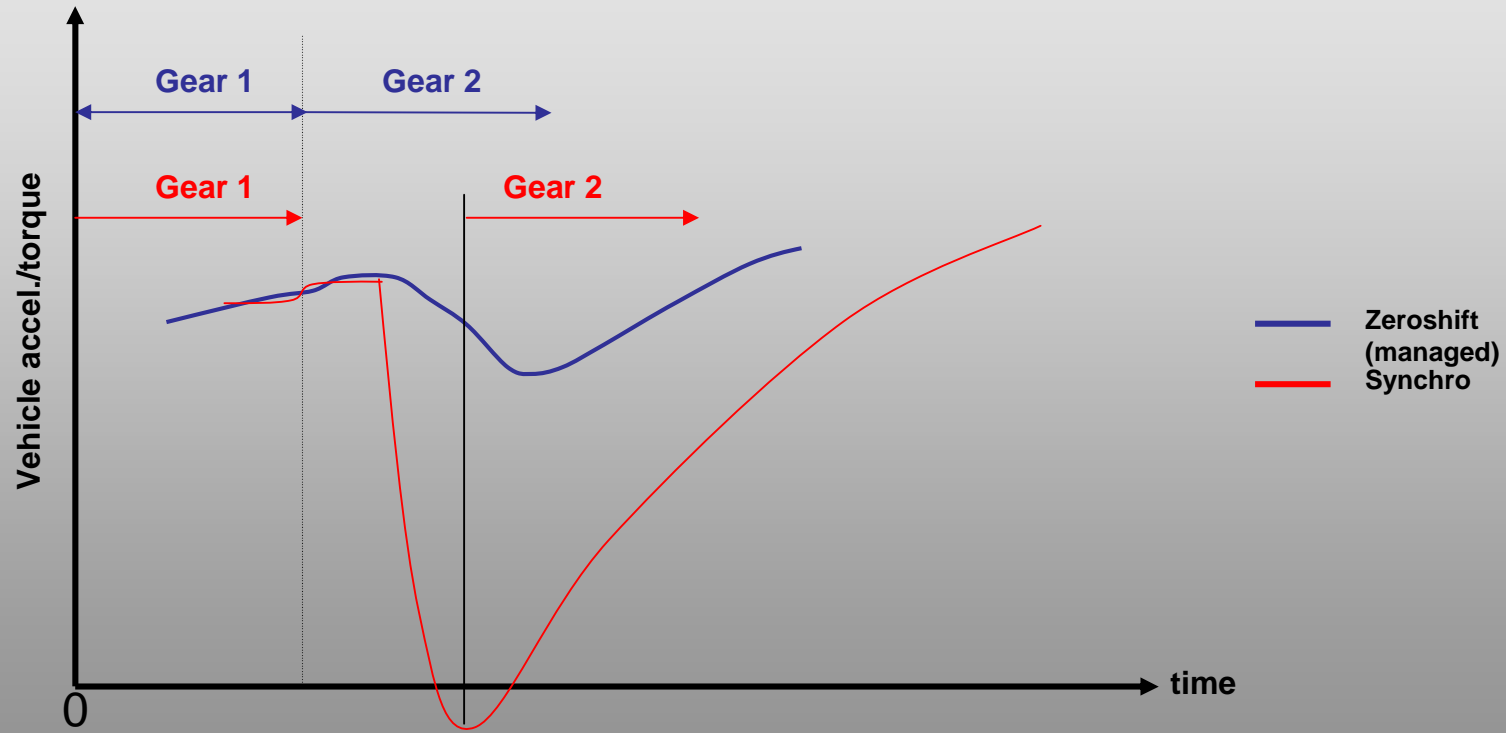

ZEROSHIFT

Professional
MotorSport
WORLD EXPO 2006



MANAGING A 'ZEROSHIFT'

- Shift event
 - Engine and clutch management
 - Driveline compliance
- Accelerating downshifts
 - Torque roll-off required
- Decelerating upshifts
 - Throttle 'blip' required

ZEROSHIFT



PRESENTATION OVERVIEW

- Concept
- Considerations for an instant gearshift
- Development
- Managing a 'Zeroshift'
- Data collection and analysis
- Benefits

ZEROSHIFT

Professional
MotorSport
WORLD EXPO 2006



DATA COLLECTION AND ANALYSIS

Ferrari 360 – Challenge Stradale

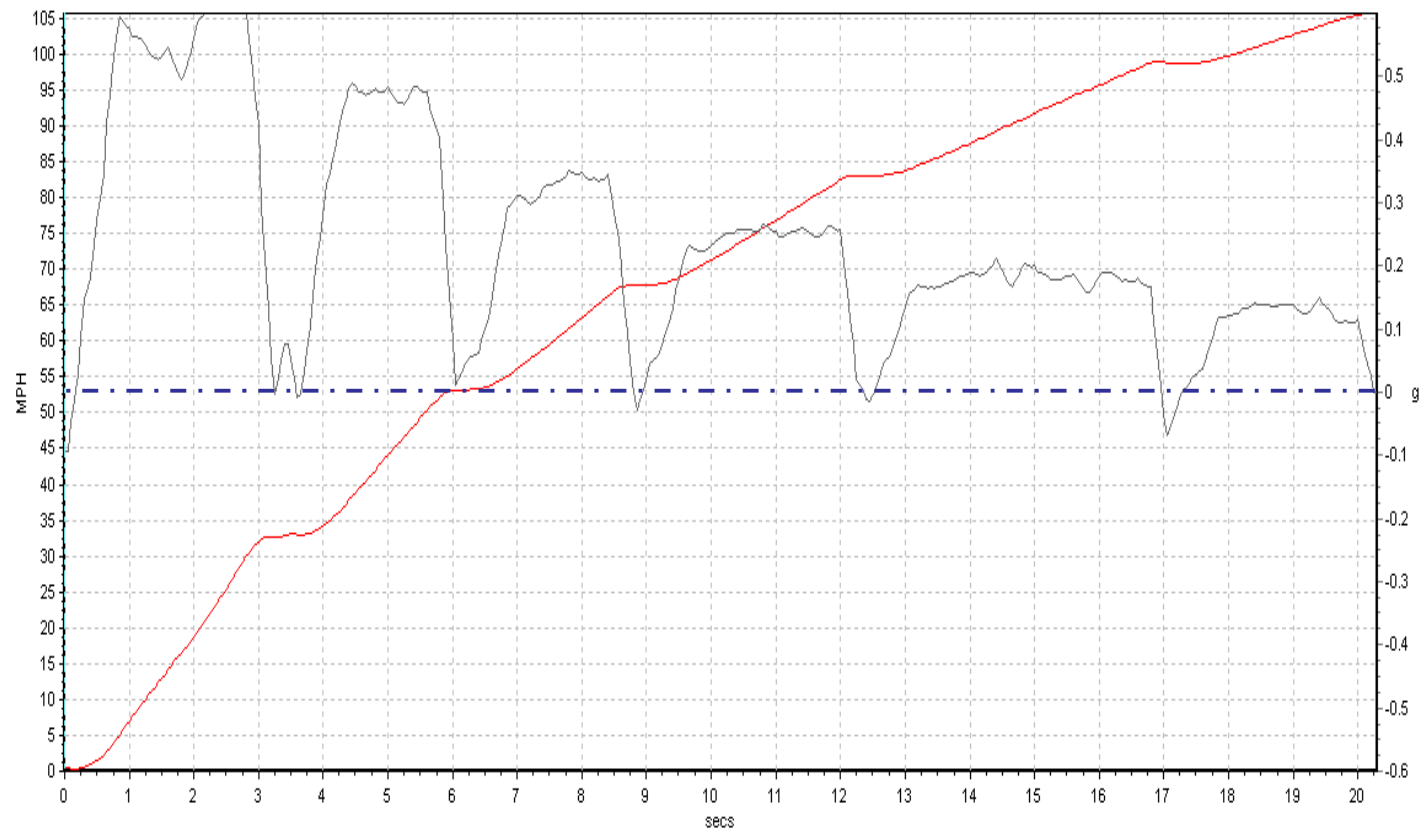

ZEROSHIFT

Professional
MotorSport
WORLD EXPO 2006



DATA COLLECTION AND ANALYSIS

Standard Manual Ford Mustang

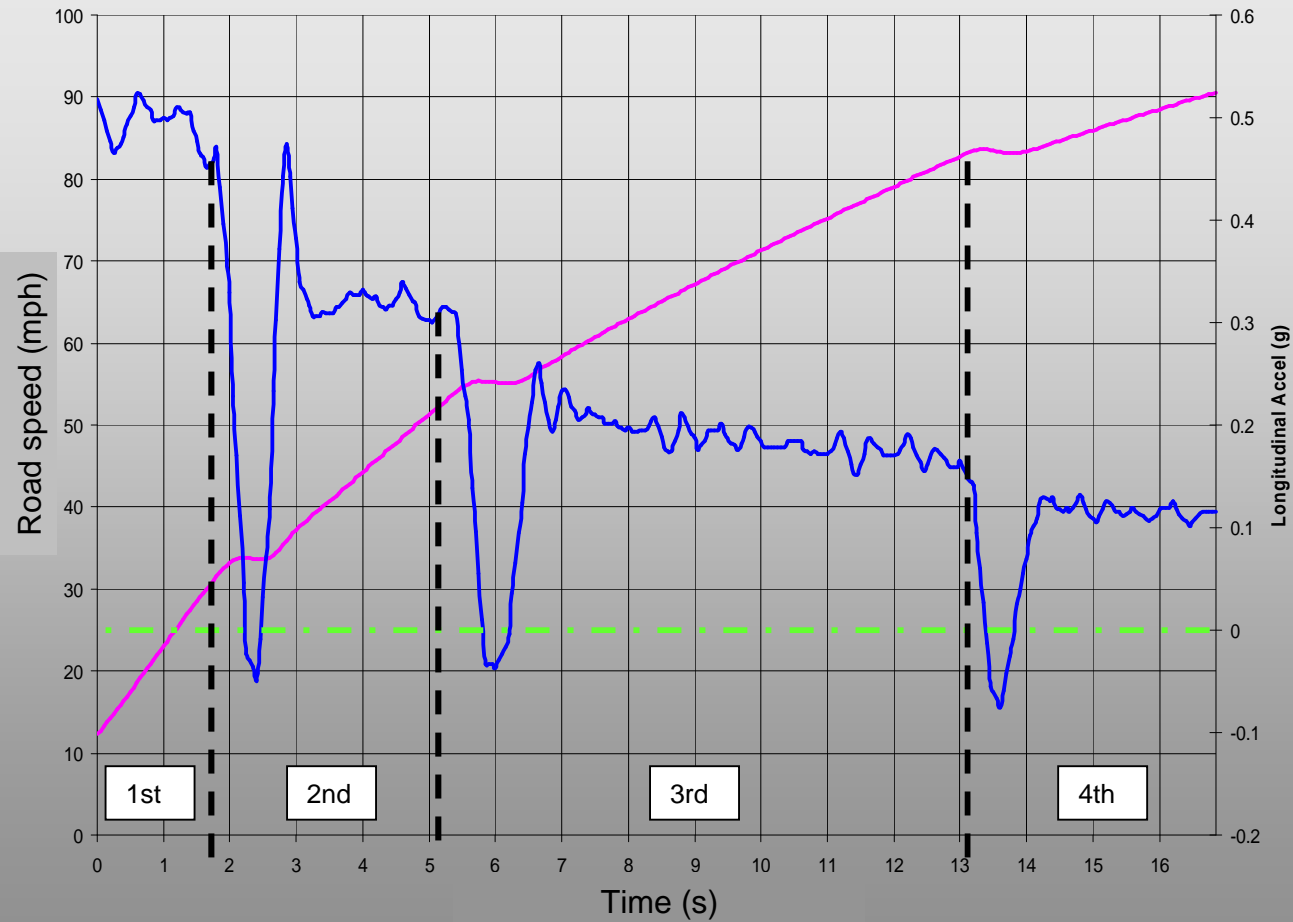

ZEROSHIFT

Professional
MotorSport
WORLD EXPO 2006



DATA COLLECTION AND ANALYSIS

Zeroshift Ford Mustang

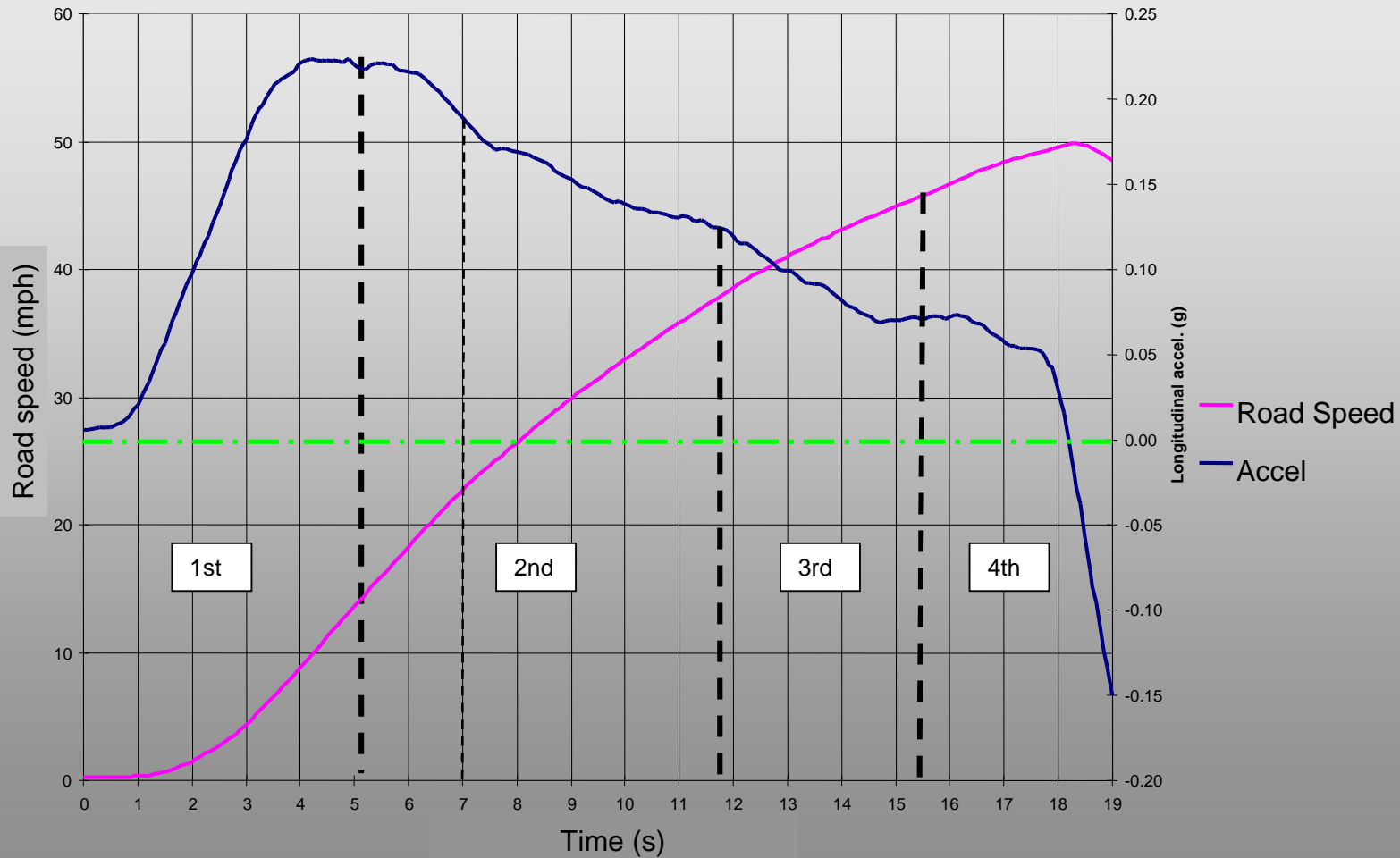

ZEROSHIFT

Professional
MotorSport
WORLD EXPO 2006



DATA COLLECTION AND ANALYSIS

Simulated Ferrari 360 AMT vs Zeroshift Ferrari 360

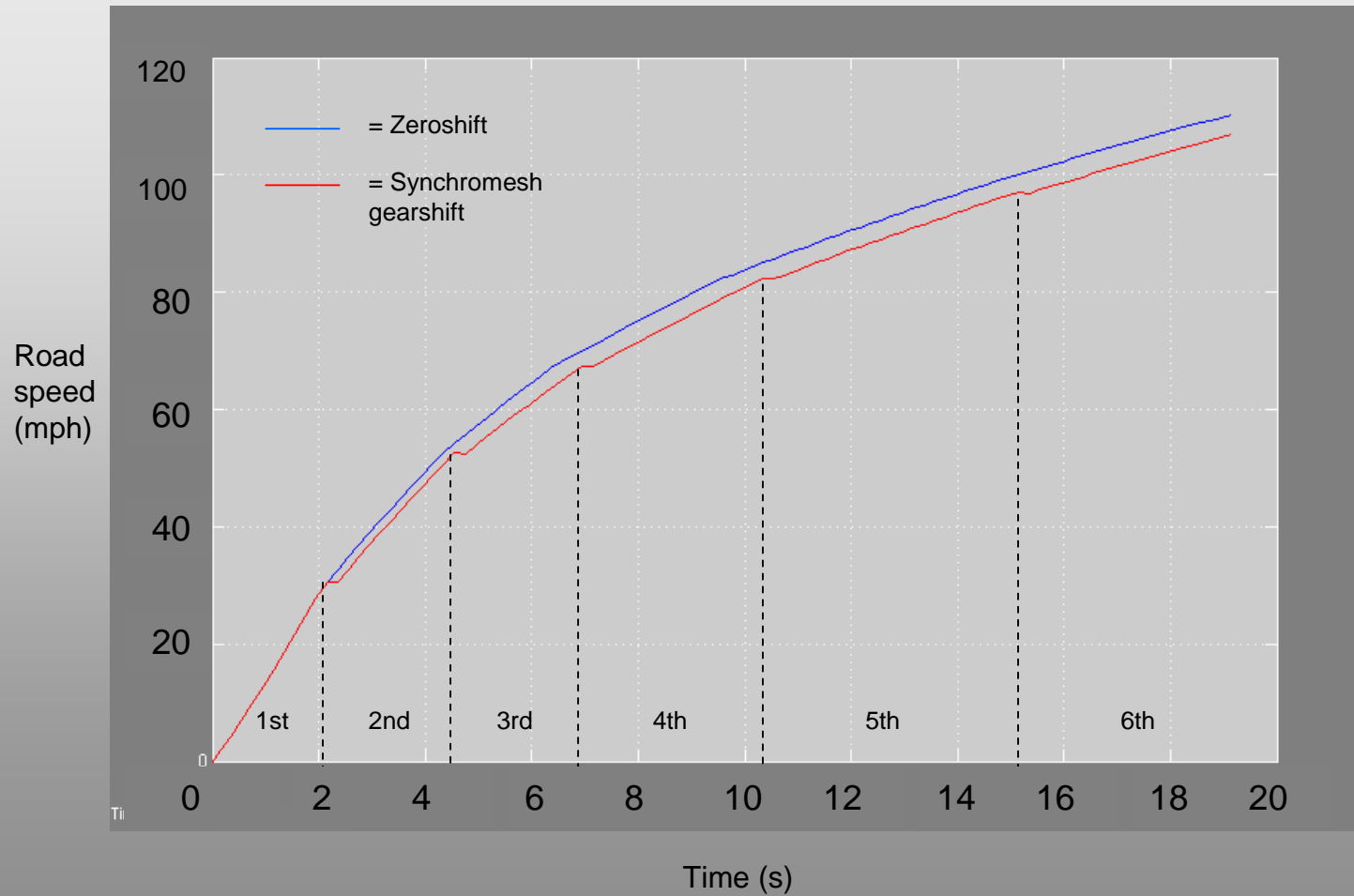

ZEROSHIFT

Professional
MotorSport
WORLD EXPO 2006



DATA COLLECTION AND ANALYSIS

Simulated Ferrari 360 AMT vs Zeroshift Ferrari 360

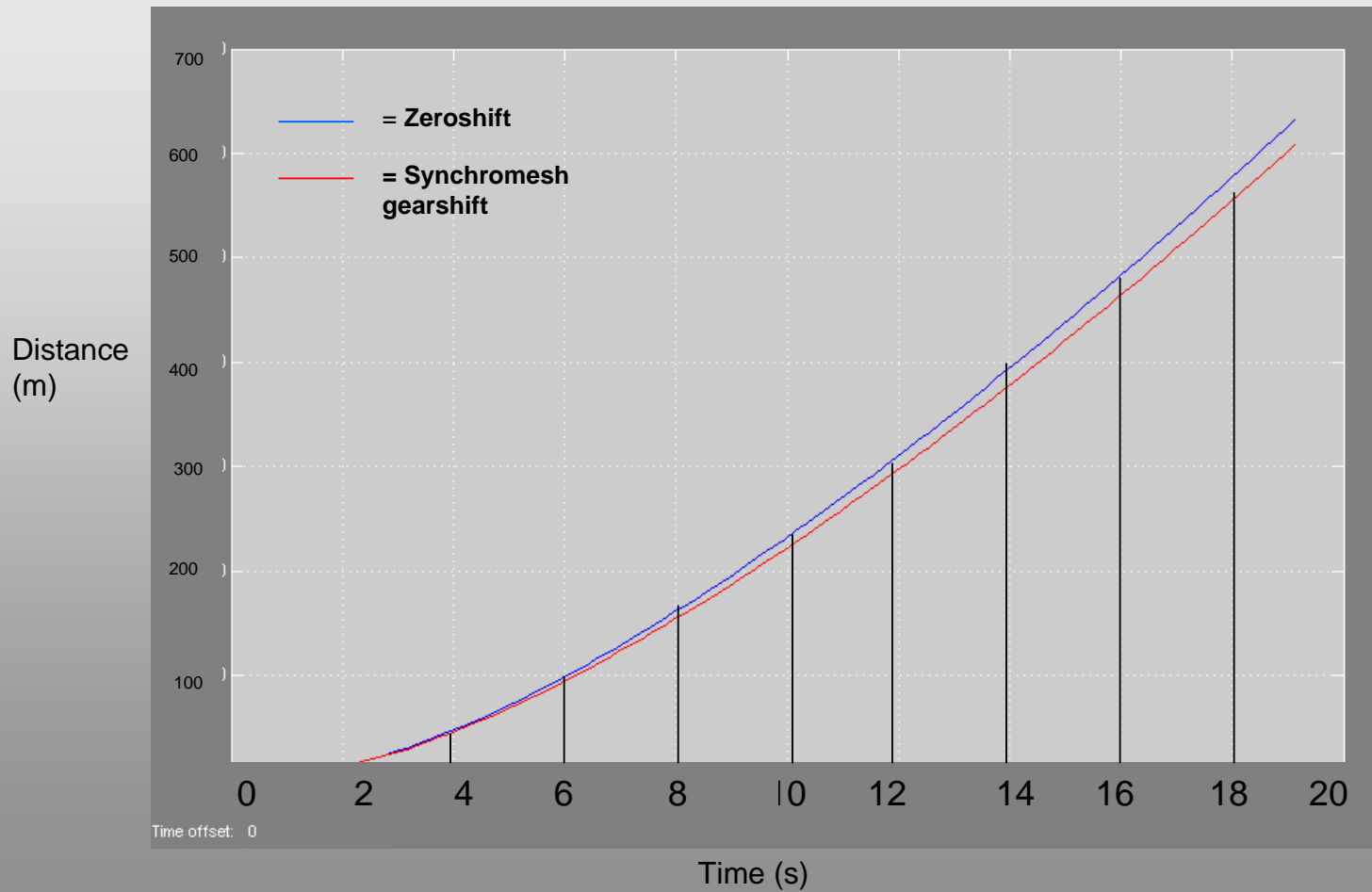

ZEROSHIFT

Professional
MotorSport
WORLD EXPO 2006



PRESENTATION OVERVIEW

- Concept
- Considerations for an instant gearshift
- Development
- Managing a 'Zeroshift'
- Data collection and analysis
- Benefits

ZEROSHIFT

Professional
MotorSport
WORLD EXPO 2006



BENEFITS

- Drivetrain dynamics

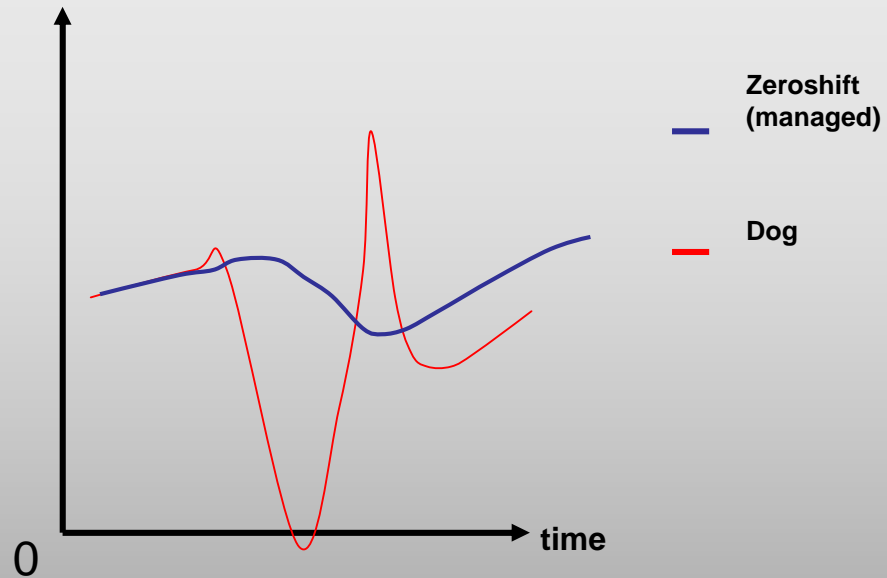

- Engine performance
 - Reduced disruption to fluid dynamics
 - Turbo lag/stall reduced

ZEROSHIFT

Professional
MotorSport
WORLD EXPO 2006



BENEFITS

- Performance and acceleration
- Shift quality
- Fuel economy/Improved range
- Vehicle dynamics — Change gear where your competitors daren't

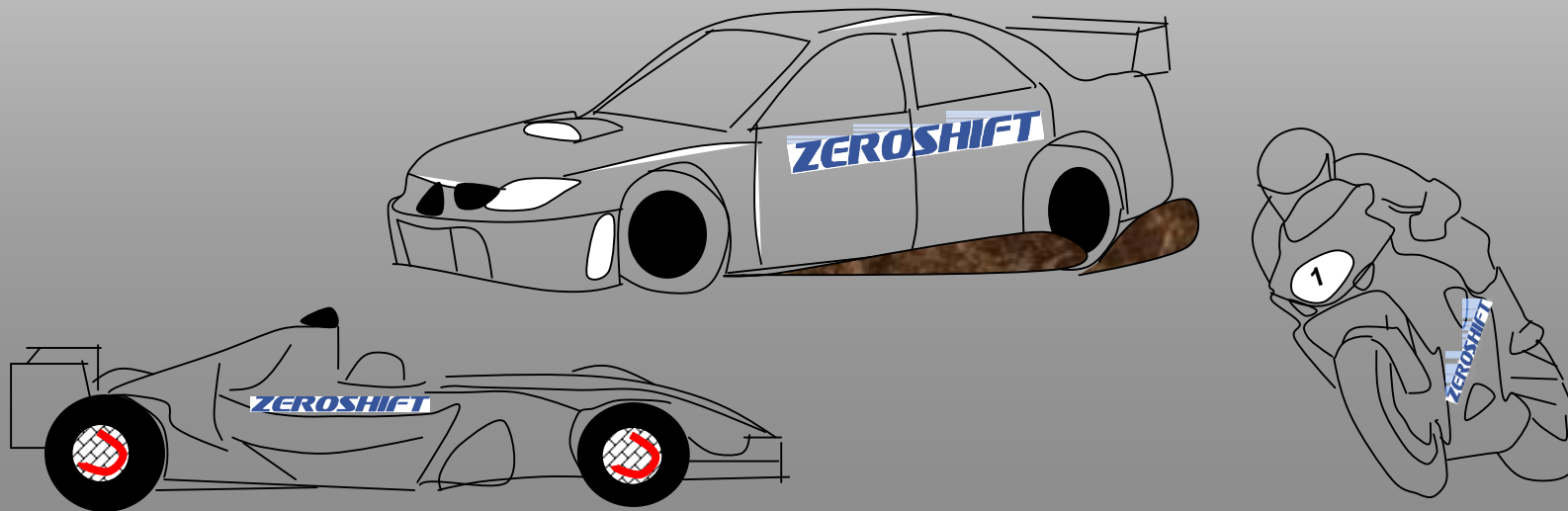

ZEROSHIFT

Professional
MotorSport
WORLD EXPO 2006



QUESTIONS

- Questions ?

www.zeroshift.com

ZEROSHIFT

Professional
MotorSport
WORLD EXPO 2006